



# JGWU & JGWUH Gas Washing Unit

**JCT**  
Analysentechnik



Gas Sampling  
Probes

Heated Sample  
Lines

Sample Gas  
Coolers

**Condensate Treatment**

Accessories

Gas Conditioning  
Systems

Sample Gas  
Converters

## APPLICATION

- Extractive gas analysis
- For heavy contaminated gases (e.g. SynGas)
- Continuous cleaning of sample gas

## BENEFITS

- Keeps sample gas clean
- Protection of gas analyzer
- Reliable removal of contamination
- Large volume for cleaning liquid

## FEATURES

- Removes contamination like tar, acids and ammonia salts
- Multiple connections:
  - sample inlet and outlet
  - cleaning liquid inlet
  - cleaning liquid outlet
  - drain outlet
- Heated sample inlet up to 200 °C (option) avoids condensation and crystallization

## TECHNICAL DATA

| Model                           | JGWU                          | JGWUH  |
|---------------------------------|-------------------------------|--|
| Description                     | liquid based gas washing unit | liquid based gas washing unit with heated sample inlet |
| Order code                      | 32.00110                      | 32.00120   |
| Option Duran glass ball filling | 35.90023                      | 35.90023   |

### Operation

|                       |                   |                   |
|-----------------------|-------------------|-------------------|
| Operating temperature | -                 | 0 °C to 200 °C    |
| Operating pressure    | -100 to 500 mbarg | -100 to 500 mbarg |
| Mounting position     | vertical          | vertical          |
| Approval / Sign       | CE                | CE                |

### Construction

|                                  |  |  |
|----------------------------------|--|--|
| Dimensions over all (WxHxD)      | 323 x 571 x 219 mm                         | 323 x 571 x 219 mm                         |
| Weight without filling           | approx. 3.5 kg                             | approx. 4.6 kg                             |
| Sample inlet                     | 1/8" NPT f                                 | 1/8" NPT f                                 |
| Sample outlet/ Liquid connection | GL18, 4/6 mm                               | GL18, 4/6 mm                               |
| Materials                        | Duran glass, SS316Ti                       | Duran glass, SS316Ti                       |
| Glass volume                     | 0.54 l (fill level cleaning liquid outlet) | 0.54 l (fill level cleaning liquid outlet) |

### Electrics

|                      |   |   |
|----------------------|---|---|
| Supply voltage       | - | 230 VAC 50/60 Hz                          |
| Power consumption    | - | approx. 500 W                             |
| Protection class     | - | IP20 (EN 60529)                           |
| Status / Alarm relay |   | Volt free contact (function programmable) |

## DIMENSIONS

Dimensions in mm

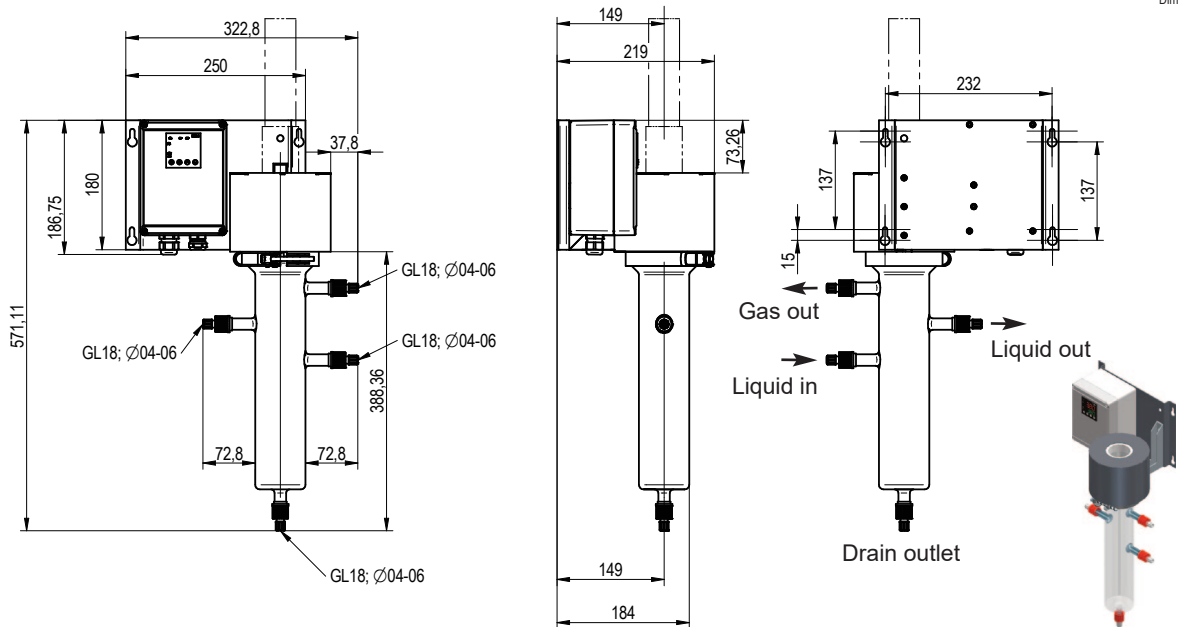

Gas Sampling Probes



Heated Sample Lines



Sample Gas Coolers



Gas Conditioning Systems



NOx Converter



and solutions for

